

**AUBERT&DUVAL**

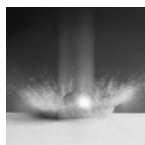

# SPACE INDUSTRY METALLURGICAL SOLUTIONS



[www.aubertduval.com](http://www.aubertduval.com)

## Equipment

### Melting

Melting furnaces (EAF, AOD, VOD)  
up to 60 tons

Vacuum Induction Melting (VIM)  
up to 20 tons

Titanium Plasma Arc Melting  
furnace (PAM-CHR)

Remelting furnaces (ESR, VAR)  
up to 30 tons

### Powder metallurgy

Gas atomization (VIM)

### Forging

Open-die forging presses  
from 1,200 to 10,000 tons

Closed-die forging presses  
from 4,500 to 65,000 tons

### Rolling mill

7-200 mm diameter bars

### Heat treatment

Solution and ageing furnaces  
Horizontal and vertical quenching  
equipment

### Testing

Immersion UT  
up to 13 tons (28,000 lbs)

Automated contact UT  
up to 20 tons

! The 65kt closed-die forging press: a world-class tool for the manufacturing of complex, large, thick and seamless parts



AUBERT & DUVAL

# The Space industry supplier of choice

A&D has been selected on major space programs for its unique combination of metallurgical expertise and know-how along with world-class melting and forging tools. This unique industrial set-up enables us to offer highly reliable and secure metallurgical solutions for the most complex, lighter, large-scaled, critical and cryogenic applications.

Thanks to this positioning, Aubert & Duval is supporting the development of the most ambitious projects: space stations, heavy or reusable launchers, spacecrafts as well as all satellite sizes.

### A unique combination to help realize your ambitions

- ! Passionate teams driven by metallurgical innovation and industrial challenges.
- ! R&T and co-engineering culture with unrivalled simulation capabilities.
- ! A unique integrated solution of world-class tools from melting to closed-die forging.
- ! Multi-material expertise: special steels, superalloys, titanium, aluminum (forging only).
- ! A multi-certified player able to support customers' needs on all markets (aeronautics, defense, nuclear): ISO 9001/EN 9100, ISO.
- ! 14001, OHSAS 18001 ; NADCAP ; AQAP2110 ; TAA experienced (US market) , Fully Authorized Economic Operator (AEO).





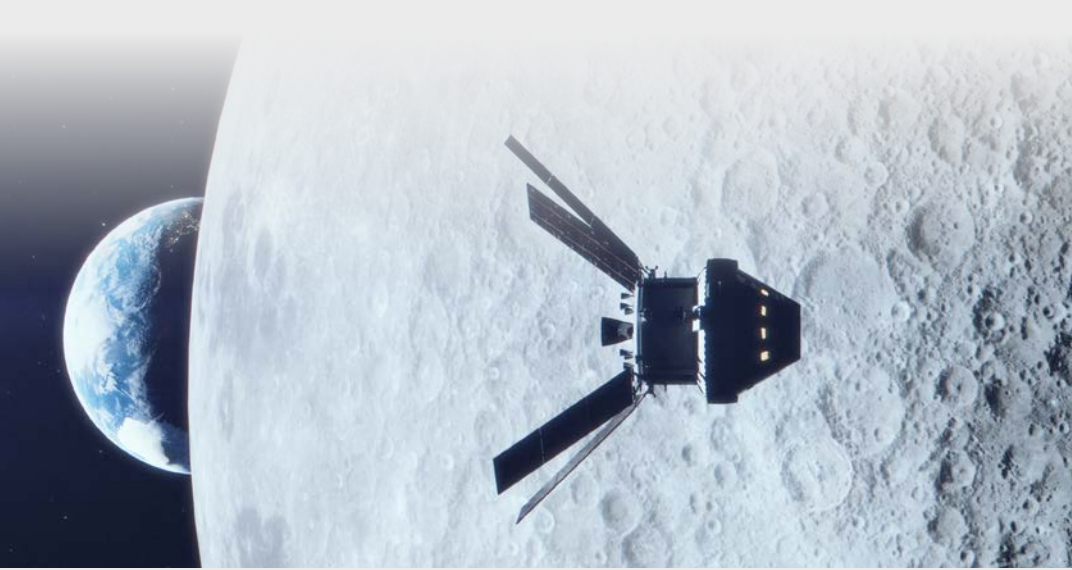

## Main materials

### HPS

High performance steels

A range of alloyed steels with tightly controlled characteristics, offering optimum value for customers.

### NiSA

Nickel-based superalloys

A range of alloyed materials with specific resistance to very high temperatures and corrosion, the majority component being nickel.

### Ti

Titanium alloys

Pure or alloyed titanium, combining mechanical properties and corrosion-resistance with light weight.

### Al

Aluminum alloys

Slightly alloyed aluminum, widely used in aircraft.

### PM

Metal powders

Steels, superalloys powders for additive manufacturing and aero rotating parts.

## Process flow

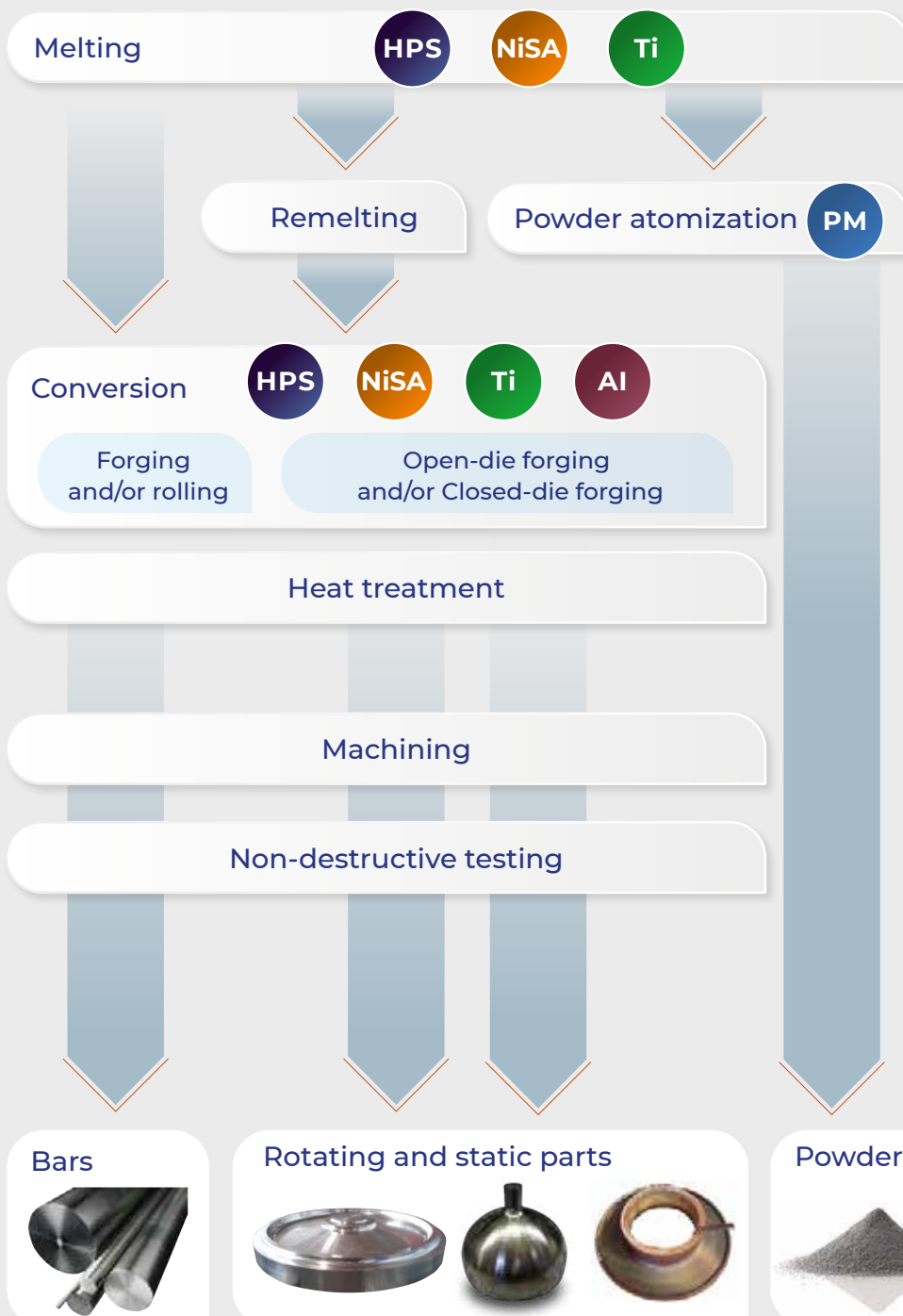

# PARTS AND BARS

## Main materials

### Al Aluminum alloys

- Al2000 series
- Al7000 series
- 5083
- 6061
- Aluminum-Lithium

### Ti Titanium alloys

AD grade	Common name
TA6V	Ti6Al4V
TA6V	Ti6Al4V ELI
Ti10 2 3	Ti10 2 3

### NiSA Nickel-based superalloys

AD grade	Common name
AD730®	NiCr16Co9Mo3W3Ti3Al2
NY276	C276 NiMo16Cr15W
PER3	Waspaloy NiCr20Co13Mo4Ti3Al
PER625	IN625 NiCr22M9Nb
PER718	IN718 NiCr19Fe19Nb5Mo3
XSH	KC20WN CoCr20W15Ni

### HPS High performance steels

AD grade	Common name
819B	35NCD16 35NiCrMo16
GKH®	32CDV13 32CrMoV12-9
M50NiL	13MoCrNiV42-16-14
Marval®18	M250 X2NiCoMo18-8-5
ML340	X23NiCoCrMoAl13-6-3
MLX®17	X1CrNiMoAlTi12-11-2
MLX®19	X1CrNiMoAlTi12-10-2
MO6ACW	D6AC 48CrMoNiV4-10
SCV®	15CDV6 15CrMoV6
X15U5W	15-5PH X5CrNiCu15-5
X18PA	X6CrNiTi18-0
XD15NW®	X40CrMoVN16-2
XDBD	440C X105CrMo17
XN26TW	A286 X6NiCrTiMoVB25-15-2

\* Patented grade

AUBERT & DUVAL

# Already on board with

**Launchers:** Ariane, Vega ESA programs ; PSLV Indian program ;

**Stations:** ISS & Axiom programs ;

**Spacecrafts:** Orion & Cygnus programs ;

Satellites: very large range of programs from LEO to GEOSAT tanks ...

And you tomorrow!

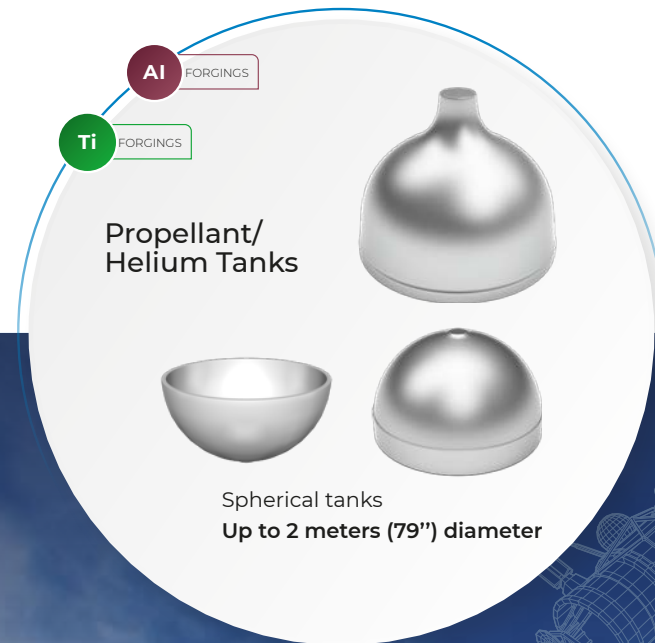

## Co-engineering

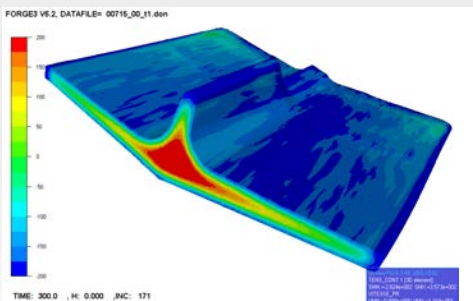

Example of residual stress after quenching

Simulation of complex, large, thick and seamless parts

- Leading expertise in residual stress - optimization and control of stress relief:
  - Allows parts to be machined without constraints
  - Allows you to eliminate the roughing and straightening steps
- A&D offers its support at the earliest stage in your development with:
  - Metallurgical know-how to obtain best mechanical properties (LH2, High T°...)
  - Co-design & input weight reduction

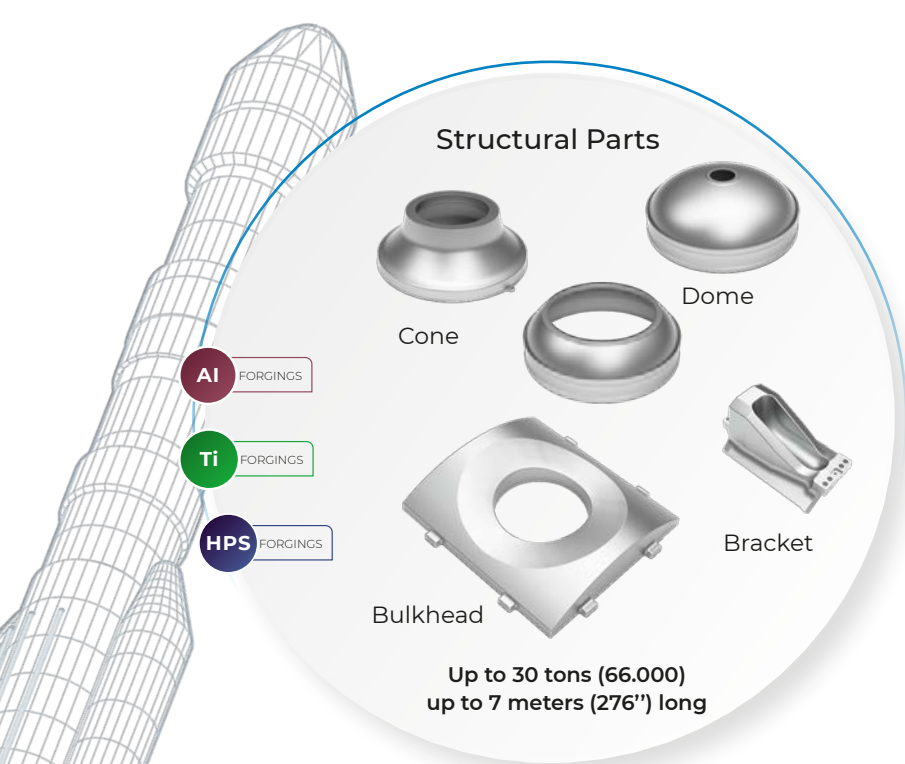

### Structural Parts

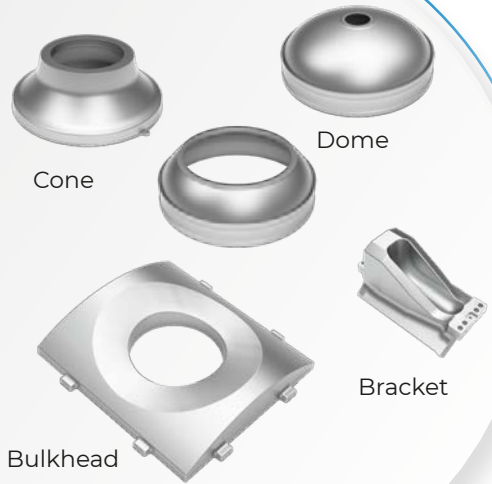

Up to 30 tons (66.000)  
up to 7 meters (276") long

- AI FORGINGS
- Ti FORGINGS
- HPS FORGINGS



### Propulsion Parts

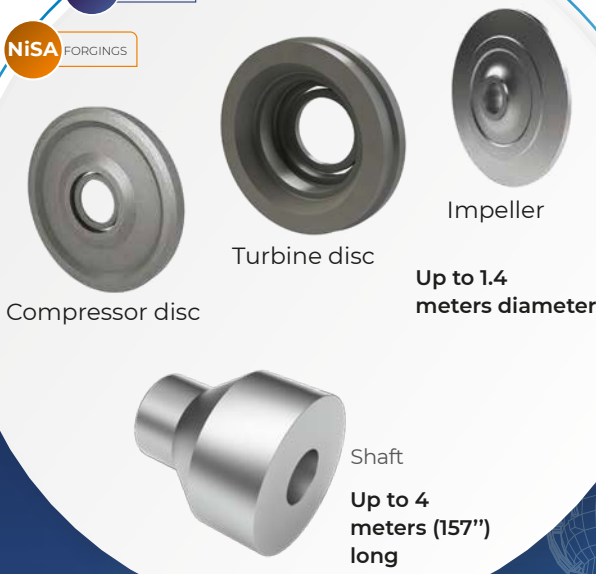

Up to 1.4 meters diameter

Up to 4 meters (157") long

- HPS FORGINGS
- NiSA FORGINGS

## Main data

### Closed-die forgings:

- ! Diameter up to 2 m / 79 in
- ! from 20 kgs / 44 lbs up to 13,000 kg / 28,600 lbs

### Open-die forgings:

- ! up to 30,000 kg / 66,000 lbs

## Bars

### Main sizes

	mm	inches
Round Bars	Ø 7.5-500	Ø 0.30-20
Flat & Square Bars	T ≤ 310	T ≤ 12
Sheets	0.6 ≤ T ≤ 150	0.2 ≤ T ≤ 6

### Surface conditions

- ! Black
- ! Peeled
- ! Ground
- ! Others

### Heat treatment conditions

- ! Annealed
- ! Hyperquenched
- ! Normalized
- ! Heat solution treated
- ! Heat treated
- ! Aged

## Innovation

We continuously develop new processes and grades to help face the challenges of the space industry.

### HPS ML340

Duplex hardening grade specifically adapted for high temperature turbine shafts (450°C/840°F), requiring 2230 MPa/323 Ksi resistance. Benefits: weight savings, improved engine efficiency & gas consumption.

### NiSA AD730®

Fully innovative nickel-based superalloy withstanding higher temperatures (750 °C / 1,382 °F) while reserving strength, creep and fatigue resistance at a competitive cost.

### AI Aluminum-Lithium alloys

Allowing weight gain up to 4% with static properties equivalent or higher than 7010/7050 & improved fatigue and rigidity properties over 10%.

### PM ABD®-900AM, ABD®-1000AM and AD730® (see pages 6-7)

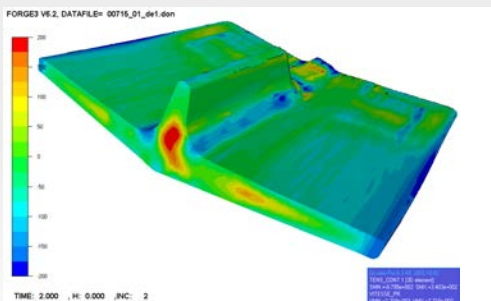

Example of residual stress elimination after cold-work



AUBERT & DUVAL

# A complete metal powder offer for additive manufacturing

## PM Main materials

### NiSA Nickel-based superalloys

- ▶ ABD®-900AM\*
- ▶ ABD®-1000AM\* **NEW**
- ▶ AD730®
- ▶ HX
- ▶ InvHard
- ▶ Ni247
- ▶ Ni625
- ▶ Ni718
- ▶ Ni738
- ▶ X15TN® **NEW**

\* : in partnership with Alloyed



**Over the years,** Aubert & Duval has acquired a deep and thorough knowledge in the design and optimization of metal powders in order to meet customers' most stringent requirements, particularly for air industry and space applications. We support space equipment manufacturers in achieving success in powder development for series production in their additive manufacturing.

Our research centers and development teams are dedicated to developing new alloys and optimizing powder characteristics to achieve the best material performance and processability for all additive manufacturing technologies.

## The performance of our powders at the heart of your additive manufacturing success

Thanks to our long-standing experience serving the space industry, we can offer tailored metal powder, including design of the chemical and mechanical properties, in accordance with space requirements.

We help our customers in the definition of metal powder specifications in order to develop suitable solutions for space applications for propulsion and structural parts for use at higher temperature and for higher trust & weight savings.

## Powder sizes

Laser Beam Melting:  
• 10-53 or 15-63  $\mu\text{m}$

Electron Beam Melting:  
• 45-106  $\mu\text{m}$

Direct Energy Deposition:  
• 45-90  $\mu\text{m}$

Customized particle size distributions available upon request



## Our Atomization Process

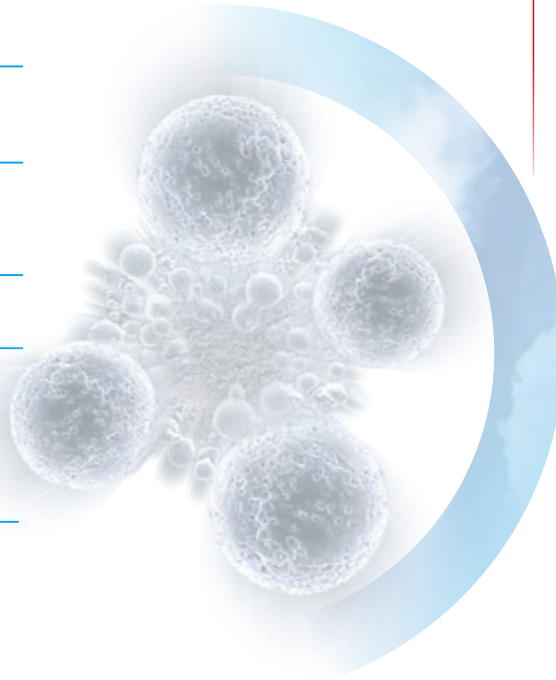
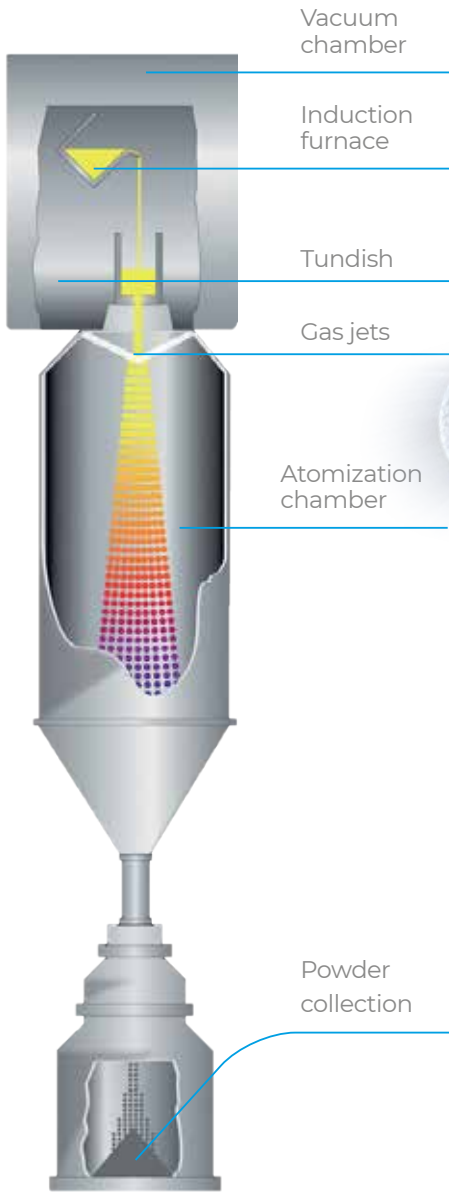

### Key features of our Atomization Equipment

- | Melting in VIM
- | N- or Ar-atomization
- | High cleanliness level
- | Highly spherical powder morphology
- | Fully-controlled low oxygen and carbon levels
- | Minimize porosity internally and of satellites
- | High stability and reproducibility

## Quality Control

With 40 years of experience in high quality gas-atomized powders, Aubert & Duval has a high level of expertise and also dedicated laboratory equipment ensuring the highest quality for powders:

- | Powder size distribution: by sieving and laser diffraction
- | Morphology: SEM pictures
- | Chemical composition: ICP, GDMS & fusion
- | Absorption Spectrometer (GFAAS)
- | Other physical properties: density, flowability



## Quality and certifications

- | EN 9100
- | ISO 9001
- | Customer accreditations



## Powders for AM Technology

Our metal powders are designed for the full range of additive manufacturing processes:

### Powder Bed

- Laser Beam Melting
- Electron Beam Melting
- Binder Jetting & Sintering

### Blown Powder

- Laser Metal Deposition
- Cold Spray

*Combustion chamber for rocket engine. ABD®-900AM powder inside. Courtesy of Airborne Engineering, Alloyed and Renishaw*





# AUBERT & DUVAL

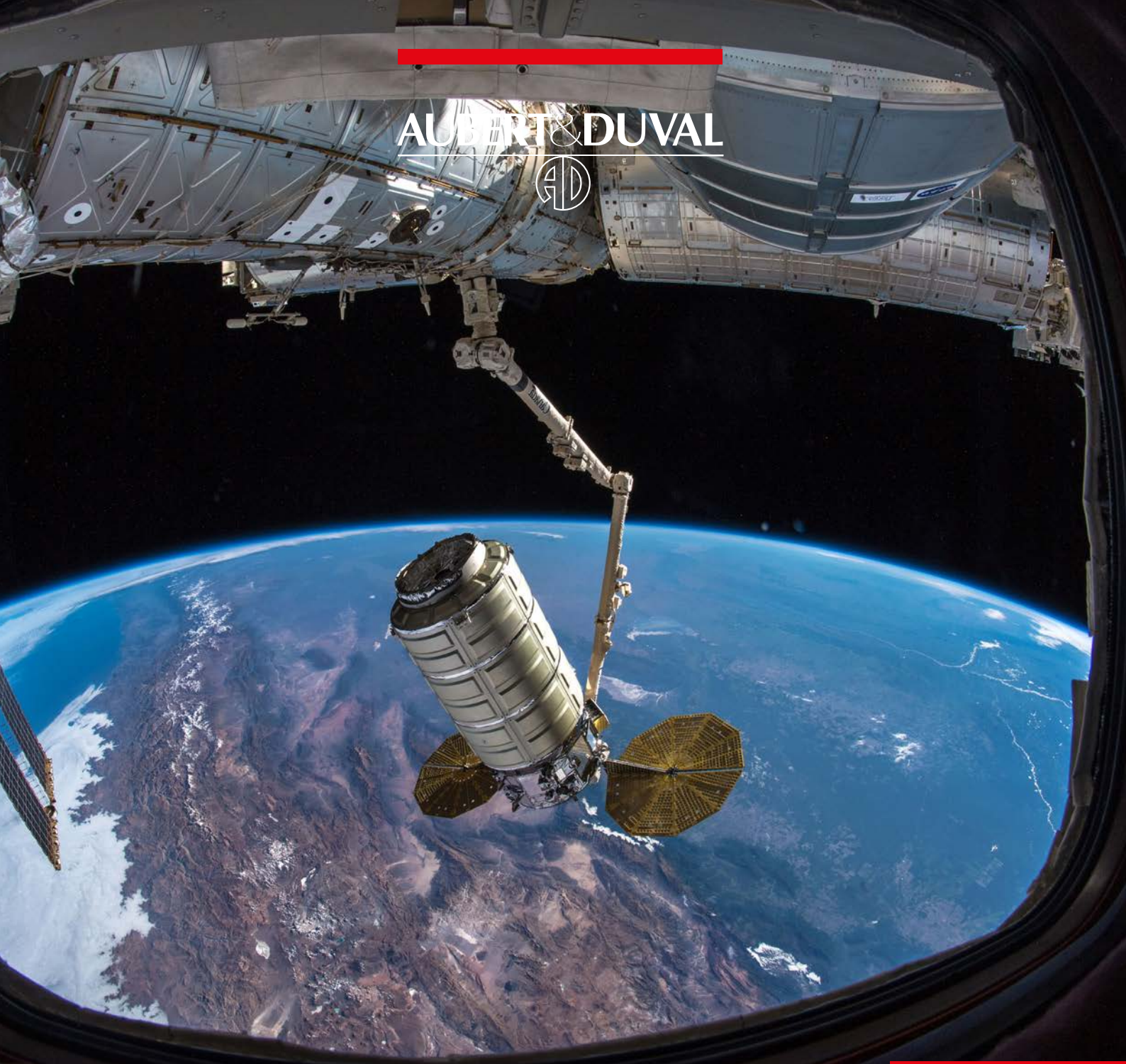

Design by  **irweego** [www.irweego.com](http://www.irweego.com) - Aubert & Duval - 10-2024  
Photo credits: A. Chassin, Nasa, Shutterstock,

The information and the data presented herein are typical or average values and are not a guarantee of maximum or minimum values. Applications specifically suggested for materials described herein are made solely for the purpose of illustration to enable the reader to make their own evaluation and are not intended as warranties, either express or implied, of fitness for these or other purposes. Aubert & Duval's liability shall not extend, under any circumstances, to the choice of the Product and its consequences.

[www.aubertduval.com](http://www.aubertduval.com)